

## Rooftop Support Block With Strut - RSB-10S

Channel support is designed for superior support of gas and refrigeration piping systems, cable tray, electrical conduit, multiple lines, HVAC equipment and many other applications. It is UV resistant and suitable for installation on most types of roofing material or other flat surfaces. Can be used as a curb (sleeper) replacement.

**Sizes:** 1-5/8" x 13/16"

**Material:** Pregalvanized Strut

**Weight (lbs):** 5.2

**Static Load Capacity (lbs):** 750

### Features

- Made from High Grade Recycled Rubber
- Green Reflector for High Visibility and Safety

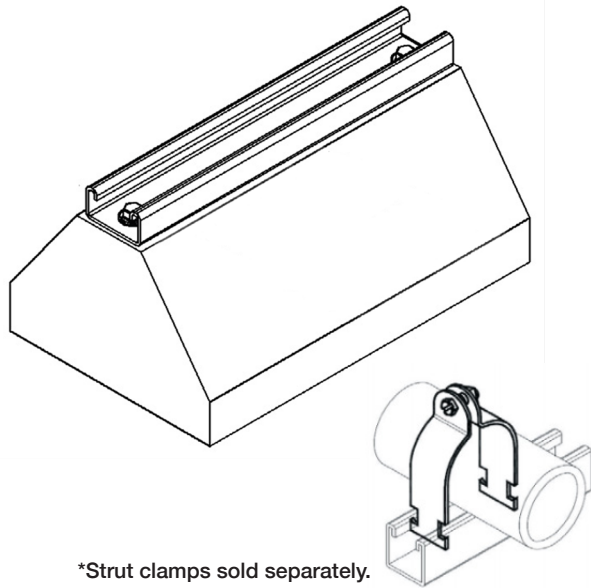

\*Strut clamps sold separately.

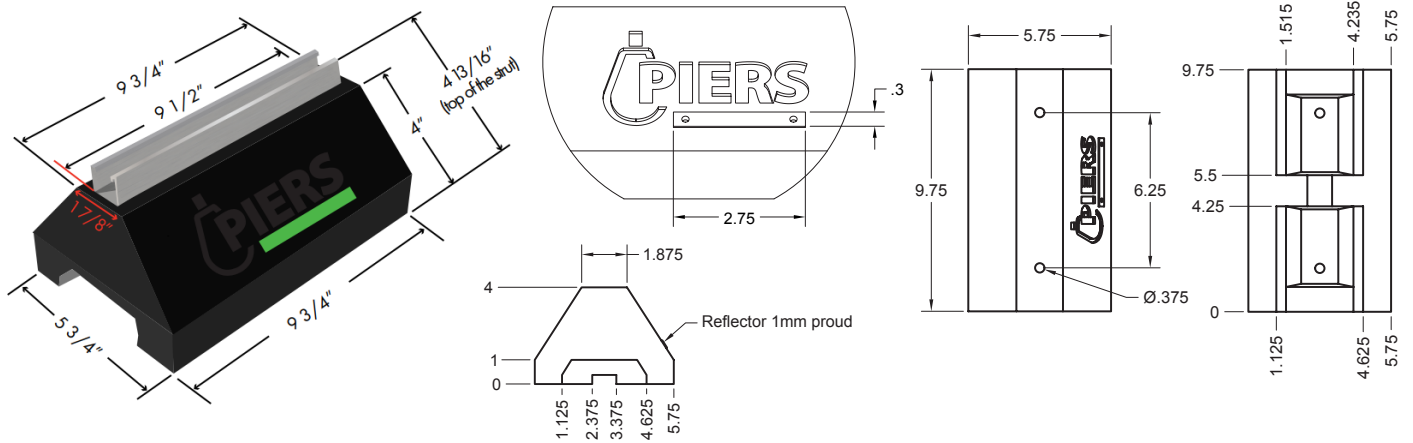

### Engineer's Approval

Job Name / # \_\_\_\_\_

Contractor \_\_\_\_\_ Date \_\_\_\_\_

Job Location \_\_\_\_\_

Engineer \_\_\_\_\_ Date \_\_\_\_\_